

WD



Axial decorative fans for exhaust ventilation with the capacity up to 302 m³/h

Applications

- Continuous or periodic exhaust ventilation of bathroom, showers, kitchens and other utility spaces.
- Ventilation shaft mounting or duct connection.
- Low to medium air flow motion for short distances at low air resistance.
- Compatible with Ø 100, 125 and 150 mm air ducts.

Design

- Modern design and aesthetic look.
- The casing and the impeller are made of high-quality durable ABS plastic, UV resistant.
- The intellectual impeller design makes the fan efficiency high and the service life long.
- Decorative replaceable colour covers: light blue, bright green, yellow and pink.
- Protection rating IP 24.

Motor

- Reliable and low-watt electric motor.
- Designed for continuous operation and requires no maintenance.
- Equipped with overheating protection.

Modifications and Options

WD alumat – fan with a matt gray painted front plate



WD K – fan is equipped with a backdraft damper for back flow preventing



WD L – the motor is equipped with ball bearings for long service life at any angle. The bearings are mounted for free and contain enough grease for the entire operating period.



WD turbo – high-powered motor



WD 12 – modification with low-voltage motor. 12 V AC power supply



WD T – equipped with a regulated timer with the operating time from 2 to 30 minutes.



WDTH – equipped with a timer with the operating time from 2 to 30 minutes and a humidity sensor with the threshold value from 60 to 90%.



WD V – equipped with a pull cord switch



WDT – equipped with a pull cord switch and a regulated timer with the operating time adjustable from 2 to 30 minutes.



WDVTH – equipped with a pull cord switch, regulated timer with the operating time adjustable from 2 to 30 minutes and a humidity sensor with the operating threshold range from 60% to 90%.

Control

Manual:

- The fan is controlled by a room light switch. It is not included in the delivery package.
- The fan is controlled by the built-in pull cord switch **V**. Not applied in case of ceiling mounting.
- Speed control is possible through a thyristor speed controller (see Electrical Accessories). Several fans may be connected to the same controller. Speed controllers can not be connected to the fans with T, TH, TP, VT, VTH modification.

Automatic:

- By the electronic control unit **BU-1-60** (see Electrical Accessories). The control unit is supplied separately.
- By the timer **T** (the built-in run-out timer enables the fan operation within 2 to 30 minutes after the fan switching off).
- By the humidity sensor and timer **TH** (if the humidity level in the room exceeds the sensor threshold adjustable value within 60-90% the fan switches automatically on and operates until the humidity level drops to the standard level, after that the fan continues operating within the time period according to the timer setting, then shuts down).

Mounting features

- The fan is mounted directly into the ventilation shaft.
- Flexible duct application is recommended in case of remote location of the ventilation shaft. The air duct is connected to the fan exhaust flange through a clamp.
- Fixed to wall by self-tapping screws.
- Suitable for ceiling mounting.
- For 12 V low-voltage motor fan connection to 220 V / 50 Hz power mains use the step-down transformer TRF 220/12-25 that is available upon separate order.

Accessories

Air ducts



Grilles and hoods



Backdraft damper



Speed controllers



Clamps



Aerodynamic characteristics

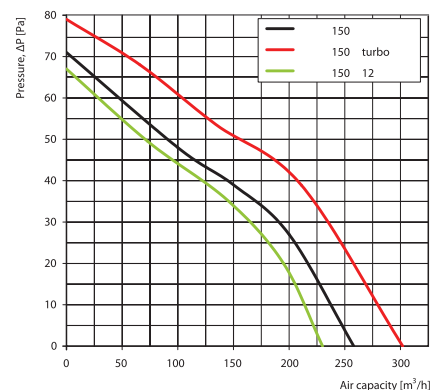
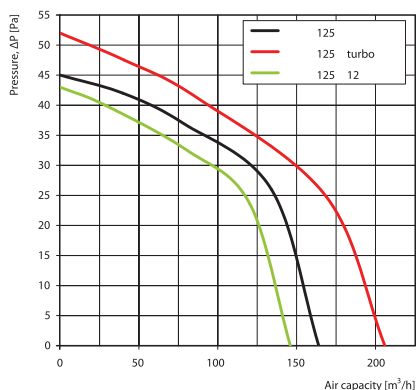
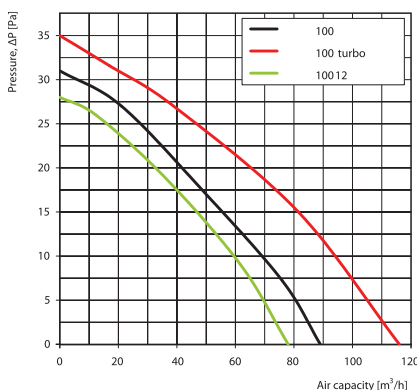

Technical data

Model	Frequency [Hz]	Voltage [V]	Power Consumption [W]	Current [A]	R.p.m.	Maximum air capacity [m ³ /h]	Sound Pressure Level at 3 m [dB(A)]	Weight [kg]
WD 100	50/60	220-240	14	0,085	2300	89	33	0,61
WD turbo 100	50/60	220-240	16	0,1	2300	116	36	0,69
WD 12 100	50/60	12	14	1,5	2200	78	32	0,60
WD 125	50/60	220-240	16	0,1	2400	164	34	0,75
WD turbo 125	50/60	220-240	24	0,105	2400	206	36	0,83
WD 12 125	50/60	12	16	1,7	2300	146	33	0,73
WD 150	50	220-240	24	0,13	2400	258	37	0,94
WD 150 (220-240 B/60 Hz)	60							
WD turbo 150 ((220-240 B/60 Hz	50	220-240	29	0,13	2400	302	39	1,08
WD turbo 150 ((220-240 B/60 Hz	60							
WD 12 150	50	12	29	2	2300	230	36	0,90
WD 150 (12 B/60 Hz)	60							

Mounting example



Overall dimensions

Model	Dimensions [mm]				
	Ø D	B	H	L	L1
WD 100	100	152	120	125	30
WD 125	125	177	140	143	42
WD 150	150	205	165	160	42

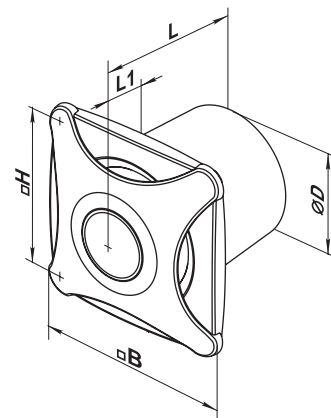

Certificates

